

MAESTRO AIR

AIR PURIFIER

User Guide



Please read these instructions carefully and keep them for future reference

WARNINGS - Please Read Carefully

This product should be used only in accordance with the instructions outlined in this manual. When using electrical appliances, basic precautions should always be followed to reduce the risk of fire, electric shock, and injury to persons, including the following:

- To avoid fire or shock hazard, plug the appliance directly into a 220 - 240 volt AC electrical outlet.
- To avoid fire hazard, NEVER put the cord under carpets or rugs or near heaters, radiators, open fires or stoves.
- DO NOT immerse in water or other liquids. DO NOT use near water.
- Children cannot recognize the hazards associated with the usage of electrical appliances. For this reason, always supervise children when they are near the air purifier.
- Always unplug the air purifier before moving it, opening the grill, changing filters, cleaning, or whenever the air purifier is not in use. When unplugging, pull by the plug and not the cord.
- DO NOT route cord under furniture or appliances. Arrange cord away from traffic areas and where it will not be tripped over.

- NEVER drop or insert any object into any openings.
- DO NOT operate any appliance with a damaged cord or plug, if motor fan fails to rotate, after the appliance malfunctions, or if it has been dropped or damaged in any manner.
- This appliance is intended for household use. Any other use is not recommended and may cause fire, electric shock, or injury.
- DO NOT use outdoors. DO NOT place anything on top of the unit.
- NEVER block the air openings, grills or outlets.
- DO NOT place on a soft surface as this could cause the unit to tip over, blocking the air intake or outtake opening.
- DO NOT attempt to repair or adjust any electrical or mechanical functions. Doing so will void your warranty. The electronics inside the Maestro Air Purifier contains no user serviceable parts.

WARNING: TO REDUCE THE RISK OF FIRE OR ELECTRIC SHOCK, DO NOT USE THIS FAN WITH ANY SOLID-STATE SPEED CONTROL DEVICE SIMILAR TO A DIMMING SWITCH.

Overview of the Maestro Air Purifier

The Maestro Air Purifier utilises five levels of filtration technology to purify the air in your home:

Particulate Filter: This pre-filter removes dirt, dust, larger particulates and allergenic particles.

Activated Carbon Filter: Absorbs vapours, volatile gases, smells, odors.

HEPA Filter: Captures fine particulates, smoke, haze, fine pollens, and other allergens.

UVC Light Technology

Ioniser: Negative ion generator. These ions bind to positively charged dust and microbiological particles in the air and then fall to the ground.

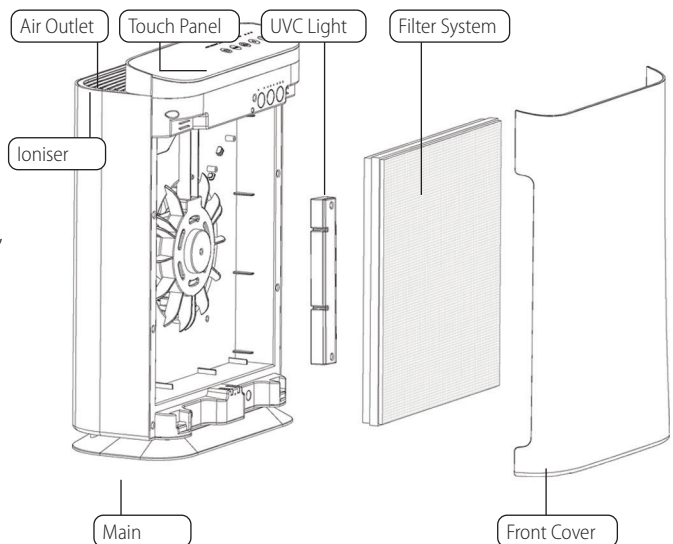

Operating Instructions

Carefully remove the air purifier from its box and plastic bag then position on a firm, level, and flat surface. For proper air flow, locate the unit at least 30 cm from any wall or furniture making sure none of the grills are obstructed or blocked.

Open the front cover of the unit and remove the Combination filter. Remove the Combination filter from its plastic bag and replace the filter to the unit ensuring that the tabs on either side of the filter are pointing outwards away from the unit. Replace the front cover of the unit and discard the plastic bag immediately. Plug the power cord into a 220 - 240V AC outlet. When moving the air purifier, always lift by the carrying handle located on back. The instructional panel on the top of the air purifier is displayed in the diagram below:

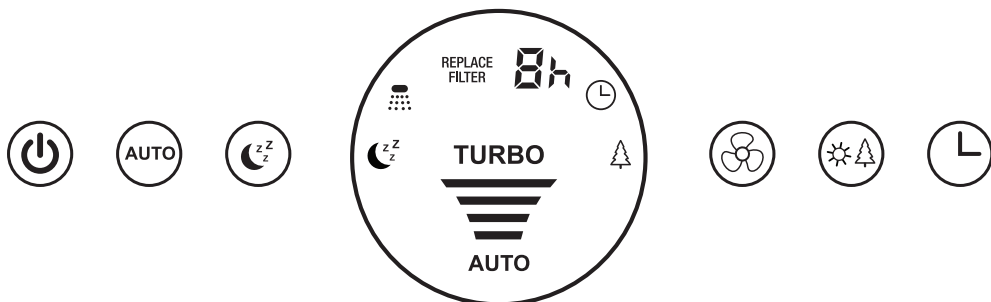

1. POWER and Filter Reset ICON

Press and release this icon to switch on or off. Press and hold this icon for 3-5 seconds to activate the Filter Reset function. The Filter Rest Function is required after the filter has been replaced.



2. AUTO ICON

Press this icon to switch Auto mode on or off. In Auto mode, the AUTO indicator is illuminated and the system automatically adjusts according to the air quality in the room.



3. SLEEP ICON

Press this icon to turn sleep mode on. The Sleep indicator will flicker for 10 seconds, then all lights will be turned off and the appliance will run on low speed. Press any icon to quit Sleep mode.



4. SPEED ICON

Press this icon to adjust fan speed to I, II, III and IV. Pressing this icon overrides the AUTO function.



5. UVC Light and Ioniser ICON

Press this icon to switch the UVC light and Ioniser on and off.

- Press once to turn on UVC light
- Press twice to turn on Ioniser
- Press three times to turn off UVC light
- Press four times to turn off Ioniser.



6. TIMER ICON

By pressing this icon, the purifier can be timed to operate for 1h, 2h, 3h, 4h, 5h, 6h, 7h, 8h, or 9h stopping automatically when time elapses.

IMPORTANT NOTE: WHEN THE MAESTRO AIR PURIFIER IS NOT IN USE, SWITCH IT OFF AND UNPLUG IT.

Display Panel

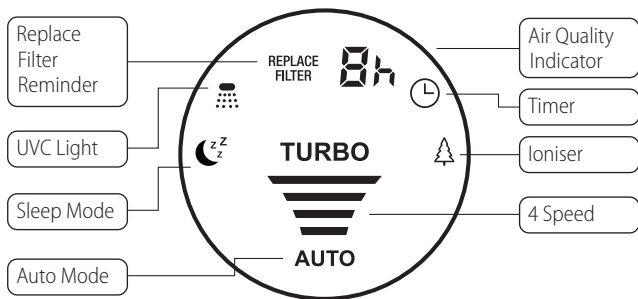

Fan Speed Indicator Lights



The air quality indicator is a ring around the display panel. The ring is illuminated in one of four colours which correspond with levels of air quality. In auto mode the fan speed adjusts to the air quality as follows:

BLUE RING - Good quality (0~49 $\mu\text{g}/\text{m}^3$). Fan adjusts to Low.

YELLOW RING - Moderate quality (50~99 $\mu\text{g}/\text{m}^3$). Fan adjusts to Medium.

ORANGE RING - Lightly polluted (100~150 $\mu\text{g}/\text{m}^3$). Fan adjusts to High.

RED RING - Heavily polluted (>150 $\mu\text{g}/\text{m}^3$). Fan adjusts to Turbo.

Installing and Removing the Combination Filter

The Combination filter incorporates three filtration technologies:

PARTICULATE FILTER: Captures dust, particulates and allergen particles.

ACTIVATED CARBON FILTER: Absorbs gases and odors.

HEPA FILTER: Captures fine particulates, smoke, pollen, and other allergens.

When the **REPLACE FILTER** indicator is illuminated on the display, the Combination filter needs to be replaced.

1. Open the front cover from the top and remove the existing Combination filter by pulling the two strips at either side at the same time.
2. Remove the new Combination filter from its packaging and insert into the unit ensuring that the two strips at either side are sticking outwards.
3. Reattach the front cover and securely latch into place.
4. Long press POWER ICON for 3~5 seconds to reset filter.

The filter will last up to 6 months depending on the air quality conditions.

Cleaning and Maintaining the Maestro Air Purifier

The Maestro Air Purifier should be cleaned once every month. Use a clean, dry, soft cloth to wipe the external surface. Do NOT stick any foreign objects or your fingers inside the unit. Do NOT use petrol, benzine, thinner, alcohol, solvents, harsh cleaners, etc. on and/or in the unit while cleaning as they will damage the product.

Ongoing Filter Maintenance

The Combination filter should also be cleaned once every month. There are 2 sections to clean, the pre-filter and the remainder of the Combination filter.

CLEANING THE PRE-FILTER:

1. Open the front cover and remove the Combination filter by pulling on the tabs as discussed previously.
2. On the front of the Combination filter is the light grey particulate filter, sometimes known as the pre-filter. The particulate filter is easily peeled off the front of the Combination filter for cleaning.
3. Clean the particulate filter with a vacuum or in a gentle hand wash.
4. Ensure the particulate filter is dry before re-attaching it to the Combination filter.

CLEANING THE COMBINATION FILTER:

1. It is best to vacuum the Combination filter outside of the home such as on a covered balcony or porch.
2. Use a vacuum cleaner to remove all loose particulates, dust and pollution. Switch on the vacuum and hold it close to the Combination filter but do not rub the nozzle along the surface of the filter.

Cleaning the Combination Filter may be required more regularly than once a month when the pollution levels in a home are high.

Specifications

220-240V, 50/60Hz, 55 Watts

2-Year Warranty

Maestro Air certifies that the Maestro Air Purifier is free from defects in material and workmanship from the date of purchase. This warranty does not cover damage caused by misuse or abuse, accident, the attachment of any unauthorized accessory, alteration to the product, or any other conditions beyond the control of Maestro Air. Maestro Air shall not be responsible for any type of incidental, consequential, or special damages. This warranty provides you with specific legal rights. You may have additional rights which may vary from state to state. Because of individual state regulations, some of the above limitations and exclusions may not apply to you. Please do not hesitate to contact:

Maestro Air

4 Pirelli Street Southport 4215

1800 616 248 | info@maestroair.com.au

Product Model: CF-8426A | Country of Origin: China

Please dispose of packaging thoughtfully and recycle where possible.